

Operator & Parts Manual

Electric Automatic Floor Scrubber

Model: DURA-18HD



CleanFreak
customerservice@cleanfreak.com
www.cleanfreak.com
888-722-5508

8021050
REV.02(05-2024)



READ THE OPERATOR MANUAL CAREFULLY BEFORE FIRST USE.

Please fill out at time of installation for future reference.

Model No. _____

Serial No. _____

Date Purchased _____

HOW TO ORDER PARTS

Only use CleanFreak supplied or equivalent parts. Parts and supplies may be ordered online, by phone, by fax or by mail.

1. Identify the machine model.
2. Identify the machine serial number from the data label.
3. Ensure the proper serial number is used from the parts list.
4. Identify the part number and quantity.
Do not order by page or reference numbers.
5. Provide your name, company name, customer ID number, billing and shipping address, phone number and purchase order number.



PROTECT THE ENVIRONMENT

Please dispose of packaging materials, old machine components such as batteries, hazardous fluids, including antifreeze and oil, in an environmentally safe way according to local waste disposal regulations.



Always remember to recycle.

CleanFreak

3900 N. Providence Ave. Appleton, WI 54913

Toll free. 888-722-5508

Local. 920-882-8453

Fax. 920-380-0878

Specifications and parts are subject to change without notice.

TABLE OF CONTENTS

SAFETY PRECAUTIONS.....4

MACHINE COMPONENTS.....6

MACHINE SETUP & INSTALLATION.....7

MACHINE OPERATION.....8

WHILE OPERATING MACHINE.....8

TANK DRAINING.....8

PREVENTATIVE MAINTENANCE.....10

BASIC TROUBLESHOOTING.....11

TECHNICAL SPECIFICATION.....12

PARTS LIST.....13-28

WEAR & TEAR PARTS LIST.....29

WIRING DIAGRAM30

SAFETY PRECAUTIONS

This machine is intended for commercial use. It is designed exclusively to scrub hard floors in an indoor environment and is not constructed for any other use. Only use recommended accessories.

All operators shall read, understand and exercise the following safety precautions:

1. Do not operate machine:

- Unless trained and authorized.
- Unless you have read and understand the operators manual.
- In flammable or explosive areas.
- If not in proper operating condition.
- In outdoors areas.

2. Before starting machine:

- Make sure all safety devices are in place and operate properly.

3. When using machine:

- Go slow on inclines and slippery surfaces.
- Follow all safety guidelines.
- Report and fix any damage to machine prior to operating it.
- Never allow children to play on or around the machine.
- Do not operate on inclines that exceed 2% (3°).

4. Before leaving or servicing machine:

- Stop on level surface.
- Turn off machine.

5. When servicing machine:

- Read operators manual thoroughly prior to operating or servicing this machine.
- Use manufacturer supplied or approved replacement parts.
- Secure machine with wheel blocks prior to jacking the machine up.
- Use approved jack or hoist to safely elevate the machine.
- Avoid moving parts. Do not wear loose fitting clothing while servicing machine.

 **WARNING: Flammable materials can cause an explosion or fire. Do not use flammable materials in tanks.**

 **WARNING: Flammable materials or reactive metals can cause explosion or fire. Do not pick up.**

SAFETY PRECAUTIONS

! WARNING: Carefully read and understand this manual before operating this machine. This machine must be grounded!

This scrubbing machine shall be grounded while in use to protect the operator from electric shock. Grounding provides a path of least resistance for electric current. This machine is equipped with a cord having an equipment-grounding conductor and grounding plug. The plug must be plugged into an appropriate outlet that is properly installed and grounded in accordance with all local codes and ordinances. Do not remove the ground pin under any circumstances.

This machine is for use on a nominal 110-volt circuit and has a grounding plug that resembles the plug illustrated in Figure. Make sure that the machine is connected to an outlet having the same configuration as the plug. No adapter should be used with this machine.

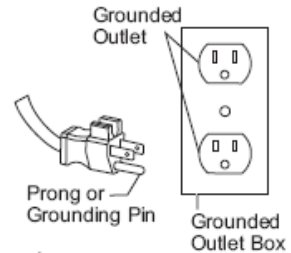

This machine is intended for commercial use. It is constructed for use in an indoor environment and is not intended for any other use. Use only recommended accessories.

1. Do not operate machine:
 - Unless trained and authorized.
 - In flammable or explosive areas.
 - With a damaged cord or plug
 - If not in proper operating condition.
 - Unless you have read and understood the operator's manual.
 - With the use of extension cords.
 - In outdoor areas and standing water.

2. Before operating machine:
 - Make sure all safety devices are in place and operating properly.

3. When using machine:
 - Do not run machine over cord.
 - Do not pull cord around sharp edges or corners.
 - Do not handle plug with wet hands.
 - Report machine damage or fault operation immediately.
 - Do not pull machine by cord or plug.
 - Do not unplug by pulling on the cord.
 - Do not stretch cord.
 - Keep cord away from heated surfaces.

4. Before leaving or servicing machine:
 - Turn off machine.
 - Unplug cord from outlet.

5. When servicing machine:
 - Unplug cord from outlet.
 - Use manufacturer supplied or approved replacement parts.

! WARNING: To avoid electrical shock, please replace the power cord immediately if any damage is being detected. The replacement must be performed only by an authorized person or by our customer service center.

! WARNING: Flammable materials can cause explosion or fire. Do not use flammable materials in tanks or pick them up.

MACHINE COMPONENTS

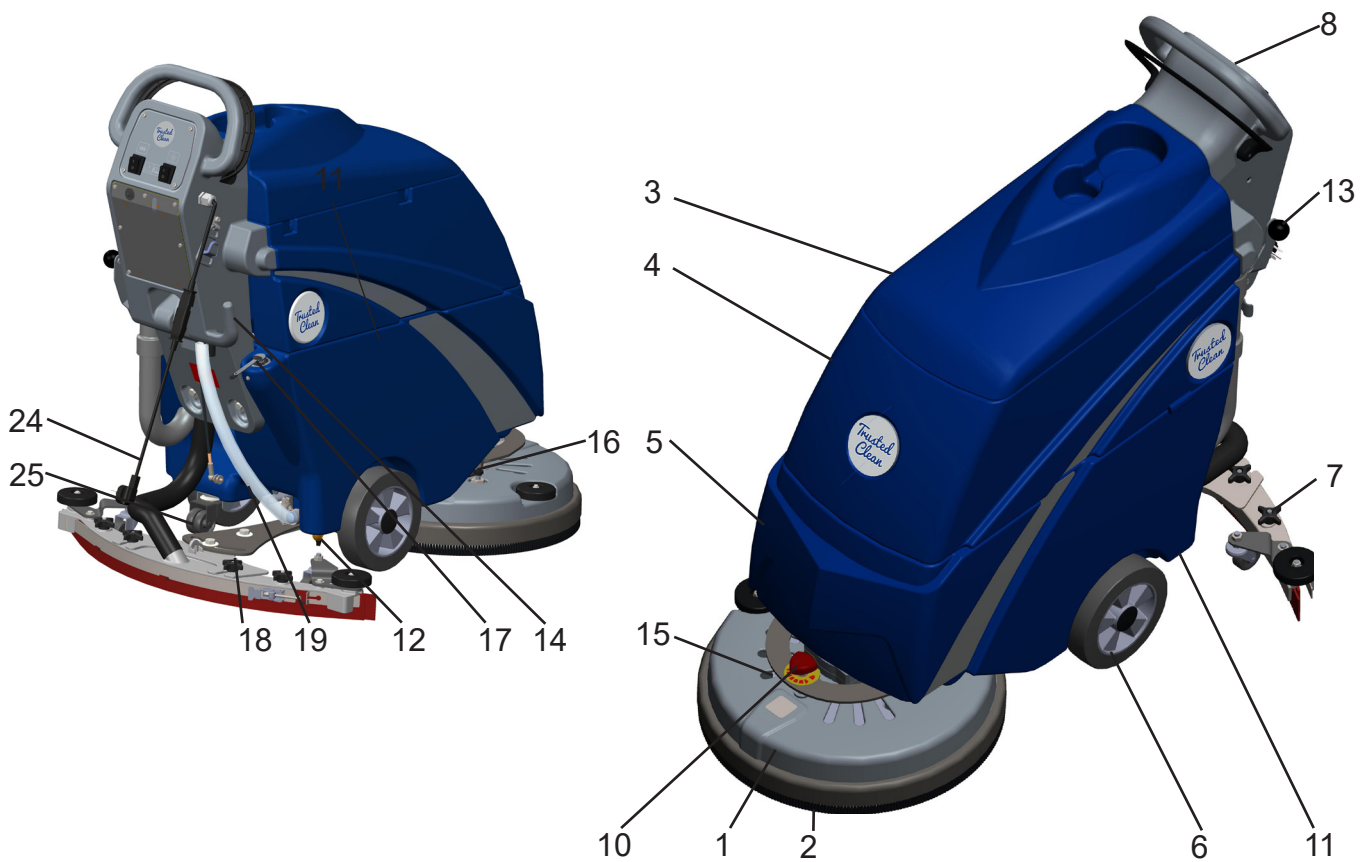
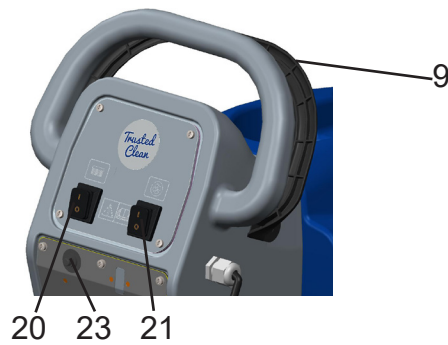

- | | | |
|-----------------------------|--------------------------------|-----------------------------|
| 1. Brush cover | 2. Brush | 3. Cover tank |
| 4. Recovery tank | 5. Solution tank | 6. 8" wheels |
| 7. Squeegee | 8. Control box | 9. Trigger |
| 10. Adjusting handle | 11. Water filter | 12. Ball valve |
| 13. Squeegee lifting handle | 14. Power cord hook | 15. Brush/pad driving hub |
| 16. Brush plunger | 17. Plug of water filling port | 18. Knob |
| 19. Clear tube | 20. Switch for brush motor | 21. Switch for vacuum motor |
| 23. Circuit breaker | 24. Power cord | 25. support wheel |

MACHINE SET UP & INSTALLATION

UNPACK MACHINE:

Be sure and check packing carton for any damage. Immediately report any damage to carrier. Be careful not to let machine vibrate while carrying, Check contents of package to ensure that the following items are included: Machine, squeegee assembly, brush/pad driver.

MACHINE SET UP & PRE-OPERATION CHECKS:

- 1) Sweep the outside of the machine.
- 2) Check that squeegee and brush / pad is properly installed.
- 3) The forward speed of machine can be controlled by turning the handle(10). Turn the handle clockwise to speed up machine. or turn the handle anticlockwise to slow down machine.
- 4) Make sure the working surface can support the machine weight, the gradient of the floor can't exceed the limit that machine allowed(2%).

INSTALLING PAD DRIVER OR BRUSH:

- 1) Turn off machine.
- 2) Tilt the machine backwards, line up the driving hub with the hole of brush or pad driver, make sure the three blocks are fitted into the three slots of the drive hub.
*If a pad driver is being used, the appropriate pad should be attached to the pad driver first.
- 3) Push the plunger which on the brush cover to prevent the driving hub from rotating, then spin the brush/pad clockwise with your another hand till the clip clamp the block on the brush/pad.

INSTALLING THE SQUEEGEE:

- 1) Loosen the two knobs(18) on the squeegee and slide the squeegee into the slots at the rear of the squeegee bracket. (the wheels on the squeegee point to the machine.)
- 2) Tighten the knobs securely.

FILLING THE SOLUTION TANK:

- 1) The fill port is located at the rear of machine, pull the plug out of the hole.
- 2) Fill solution tank with water. (use a hose which link to a water faucet, water temperature should not exceed 50° C) The clear tube(19) in the back right of the machine has gallon markers to help determine the water level in the solution tank(5).
*Depending on the dirty level of the ground, add the proper amount of detergent into the solution tank.

 **WARNING:** Do not put any flammable materials into solution tank. This can cause an explosion or a fire. Only use recommended cleaning chemicals. Contact your janitorial supply distributor for recommendations on proper chemicals.

MACHINE OPERATION



WARNING: Do not operate machine unless you have read and understand this manual.

- 1) Lower squeegee assembly to the floor by spin the squeegee lifting handle(13).
- 2) Turn brush motor switch(20) to “on” position.
- 3) Turn vacuum motor switch(21) to “on” position.
- 4) Rotate the ball valve(12) handle to vertical position. Solution will not begin to flow until the operating triggers (9) are pulled.
- 5) To begin scrubbing, pull on the blue operating trigger(9), when this trigger is pulled, the pad driver will begin to spin and the solution will begin to flow.
- 6) Begin scrubbing by moving the machine forward.
- 7) Adjust solution flow by adjusting the position of ball valve knob.



WARNING: Do not keep the machine in the same position with the pad / brush spinning, or you might damage the floor.

WHILE OPERATING MACHINE

- 1) Occasionally open the cover tank(3) to see if there is any foam build-up. If excessive foam is found, add defoamer to the recovery tank.



WARNING: Foam must not enter the float shut-off screen, or damage can occur to the vacuum motor. Foam will not activate the machine's float shut-off device.

- 2) Occasionally view the clear tube at the back left of the machine to check the amount of cleaning solution left in the machine. If the squeegee assembly leaves streaks on the floor, raise the squeegee off the floor and wipe the blades down with a damp cloth.



WARNING: Do not use your fingers to wipe or remove debris from the blades, as injury may occur.

When the solution tank runs empty, turn off the brush switch and ball valve of solution tank. Keep the squeegee down and continue to vacuum until all the dirty water is picked up.

TANK DRAINING

- 1) Turn the switches on the control panel to “off” position.
- 2) Raise the squeegee, transport machine to approved area for draining tank(s).



WARNING: Any time scrubbing is completed, or when refilling solution tank, the recovery tank should be drained and cleaned.



WARNING: If the recovery tank is not drained when the solution tank has been refilled, foam or water may enter the float shut-off mechanism and cause damage to the vacuum motor.

DRAINING THE RECOVERY (DIRTY) TANK

- 1) Remove the drain hose from the holder, and place the drain hose over the floor drain. Twist off the drain hose plug to begin the draining process.
- 2) Clean the recovery tank after every use. Use a fresh water hose to rinse out the recovery tank. Be careful not to spray water into the float shut-off mechanism.

⚠ WARNING: If you are storing the machine for any period of time, keep the cover tank open so the tank can dry completely and smell fresh.

DRAINING THE SOLUTION (CLEAN) TANK

⚠ WARNING: Any time scrubbing operation is completed, the solution tank should be drained and cleaned.

- 1) Pull down on the clear tube (back left of the machine) to remove it from the hose barb. This will allow the solution to flow freely into a bucket or floor drain.
- 2) Rinse the solution tank with clean water after every use. This will help prevent chemical buildup and clogging of the solution lines.
- 3) Once tank is rinsed, flushed and drained, reconnect the clear tube to the hose barb. Be sure the tube is pushed all the way up on the hose barb.
- 4) Screw off the cover of the water filter(11) to completely exhaust the tank and check the filter screen, clean it up if necessary.
- 5) Screw up the cover of the water filter(11), but sure to install the screen and the "O" ring in the correct position.

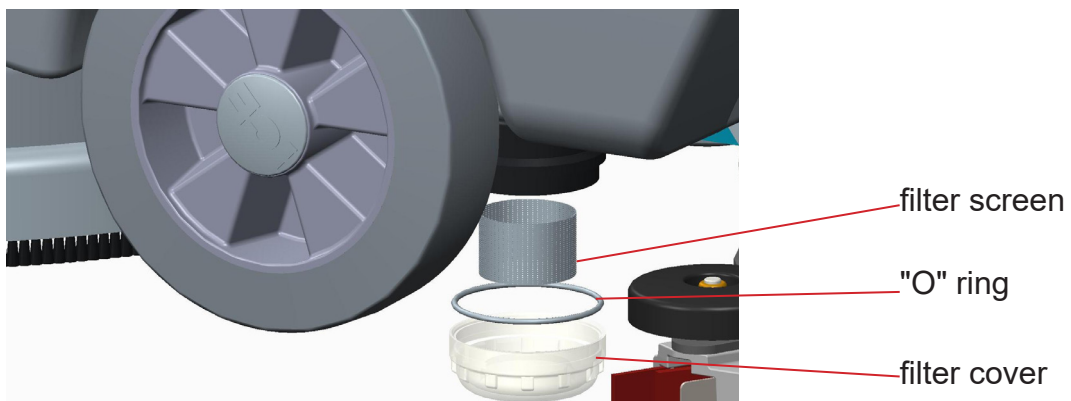

PREVENTATIVE MAINTENANCE

 **WARNING:** Before performing any maintenance on the machine, be sure that the power is turned off, or the batteries are disconnected!

 **WARNING:** Repairs are to be completed by authorized service centers only. Any repairs completed by unauthorized persons will void the warranty.

DAILY MAINTENANCE

- 1) Remove pad driver / brush and clean with approved cleaner.
- 2) Drain recovery and solution tanks completely and rinse out with clean water. Visually check the recovery tank for debris and clean out as necessary.
- 3) Raise squeegee assembly off floor and wipe it down with a damp towel. Be sure to store the squeegee in the up position.
- 4) Remove the float shut-off assembly and rinse it out with clean water.
- 5) Clean machine with an approved cleaner and a damp towel. Don't spray water to clean the outside of machine to avoid damage to motor and wiring.
- 6) Unplug vacuum motor from power source and hose cuff & remove the drain hose from the holder prior to removing the recovery tank when performing maintenance.
- 7) Check the condition of the squeegee blade wiping edge, rotate blade or replace it if worn.

MONTHLY MAINTENANCE

- 1) Inspect and clean the recovery tank cover seal. Replace it if damaged.
- 2) Lubricate all grease points and pivot points with silicon spray and approved grease.
- 3) Check the machine for loose nuts and bolts.
- 4) Check the machine for leaks.
- 5) Battery must be stored in a charged state, please charge monthly.

MOTOR MAINTENANCE

- 1) Contact your local CleanFreak Distributor for any motor maintenance.
- 2) Check the motor brushes every 250 hours, Replace the brushes when they are worn to a length of 10mm or less.

MACHINE STORAGE

- 1) Always store the machine indoors and in its upright position.
- 2) Always store the machine in a dry area.
- 3) Always take off the pad driver / brush before storage.
- 4) Always store the machine with the squeegee assembly raised off the floor.
- 5) If storing in an area which may reach freezing temperatures, be sure to drain all fluids from the machine prior to storage(include the filter). Any damage caused by freezing temperatures will not be covered by the warranty.
- 6) Drain the recovery tank and keep the cover tank open so that it can "breathe" during storage.
- 7) Drain the solution tank of all fluid.

BASIC TROUBLESHOOTING		
PROBLEM	CAUSE	SOLUTION
No Power	The wiring not connected correctly or bad wiring	Check the wiring or contact CleanFreak Distributor
	Bad brush motor	Contact CleanFreak Distributor
	Carbon brushes worn out	Contact CleanFreak Distributor
Vacuum motor does not run	The wiring not connected correctly or bad wiring	Check the wiring or contact CleanFreak Distributor
	Bad vacuum motor	Contact CleanFreak Distributor
	Carbon brushes worn out	Contact CleanFreak Distributor
Little or no solution flow	Bad ball valve	Contact CleanFreak Distributor
	Bad solution valve	Contact CleanFreak Distributor
	Ball valve position in need of adjustment	When ball valve is in horizontal position, the amount of solution flow is maximum.
Poor water pick up	Squeegee clogged	Clean debris off squeegee with a damp towel
	Squeegee blades worn	Install new squeegee blades
	Squeegee not mounted correctly	Confirm that the squeegee assembly is securely fastened to the machine and not loose fitting.
	Vacuum hoses have a hole or are loose	Check hose connections and make sure they are firm. Replace hose if damaged.
	Vacuum hose may be clogged	Check hose for debris and remove any clog.
	Drain hose stopper is loose	Tighten drain plug.
	Vacuum motor is loose	Tighten vac motor mounting screws. Do not over tighten or damage will occur.
	cover tank is loose	Confirm the cover tank is securely in its place.
	Recovery tank is full	Drain recovery tank
Float shut off is clogged	Remove float shut off from inside recovery tank and remove any debris	

TECHNICAL SPECIFICATION	
ITEM	PARAMETER
Working Width	18in / 450mm
Squeegee Width	30in / 762mm
Productivity rate	12915 ft ² h / 1200m ² h
Brush Dia.	18in / 450mm
Brush Speed	180rpm
Max Pad Pressure	55lbs / 25kg
Voltage	120VAC
Brush Motor	0.75hp / 550W
Vacuum Motor	0.7hp / 500W
Solution Tank Capacity	9.25Gal / 35L
Recovery Tank Capacity	10.57Gal / 40L
Machine Weight (w/o batteries)	138lbs / 62.5kg
Machine Length	45.87in / 1165mm
Machine Height	40.35 in / 1025mm
Machine Width	20.5in / 520mm
Power cord Length	82ft / 25m
Max Gradient	2%
Type of Drive	Brush assisted
Noise Level	70 dB
WATER LIFT - AIR FLOW	155 mbar

RECOVERY TANK GROUP

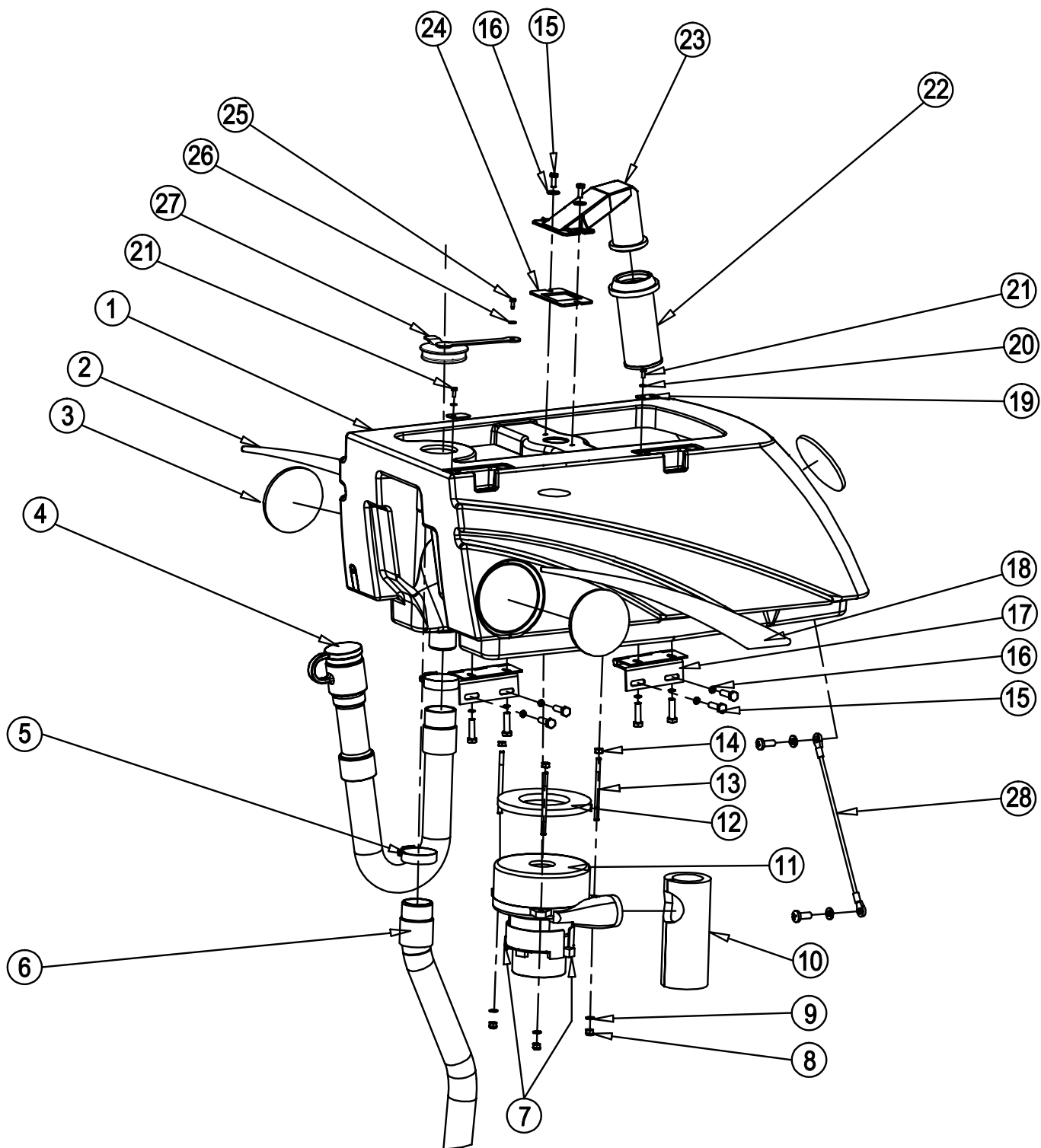

RECOVERY TANK GROUP

DIA NO.	PART NUMBER	DESCRIPTION	SERIAL NUMBER	NO. REQ'D
1	8011001B	RECOVERY TANK	51020000173—51020000421	1
	8016001B	RECOVERY TANK,Blue	18HD-000422—	1
2	8021033	DECAL,LEFT		1
3	8023007	ICE LOGO		3
4	8131010	DRAIN HOSE	18HD-000422—18HD-000493	1
	8131030	DRAIN HOSE	18HD-000494—51020001153	1
	8131031	DRAIN HOSE	51020001154—	1
5	1962050	HOSE CLAMP 27-51mm		2
6	8011006	VACUUM HOSE	18HD-000422—51020001225	1
	8011060	VACUUM HOSE	51020001226—	1
7	8211024	CARBON BRUSH		2
8	1113608	SELFLOCKING NUT M6		3
9	1411612	PLAIN WASHER $\phi 6 \times \phi 12 \times 1.6$		3
10	8011007	MUFFLER		1
11	8011200	VACUUM MOTOR 110V, 500W, KIT		1
12	8112005	GASKET		1
13	8112006	BOLT		3
14	1111605	HEX NUT M6		3
15	1021616	HEX HEAD BOLT M6 \times 16		10
16	1421618	PLAIN WASHER $\phi 6 \times \phi 18 \times 1.6$		10
17	8111300	HINGE ASSEMBLY		2
18	8021034	DECAL,RIGHT		1
19	8011009	PLATE		2
20	1421409	PLAIN WASHER 4 \times 9 \times 0.8,SS		5
21	1221410	PH SCREW M4 \times 10,SS		2
22	8111015	FLOAT CAGE		1
23	8111014	FLITER COUPLING		1
24	8111001	GASKET		1
25	1321110	AUTO TAPPING SCREW ST3.5 \times 10		1
26	1421412	PLAIN WASHER $\phi 6 \times \phi 12 \times 1.6$		1
27	8131003	CAP	51020000173—51020001225	1
	8131004	CAP	51020001226—	1
28	8011013	CABLE		1

Note:

NO 1、4、6: Supplier change, code update.

NO 27: The results are optimized and will also fit older machines.

COVER TANK ASSEMBLY

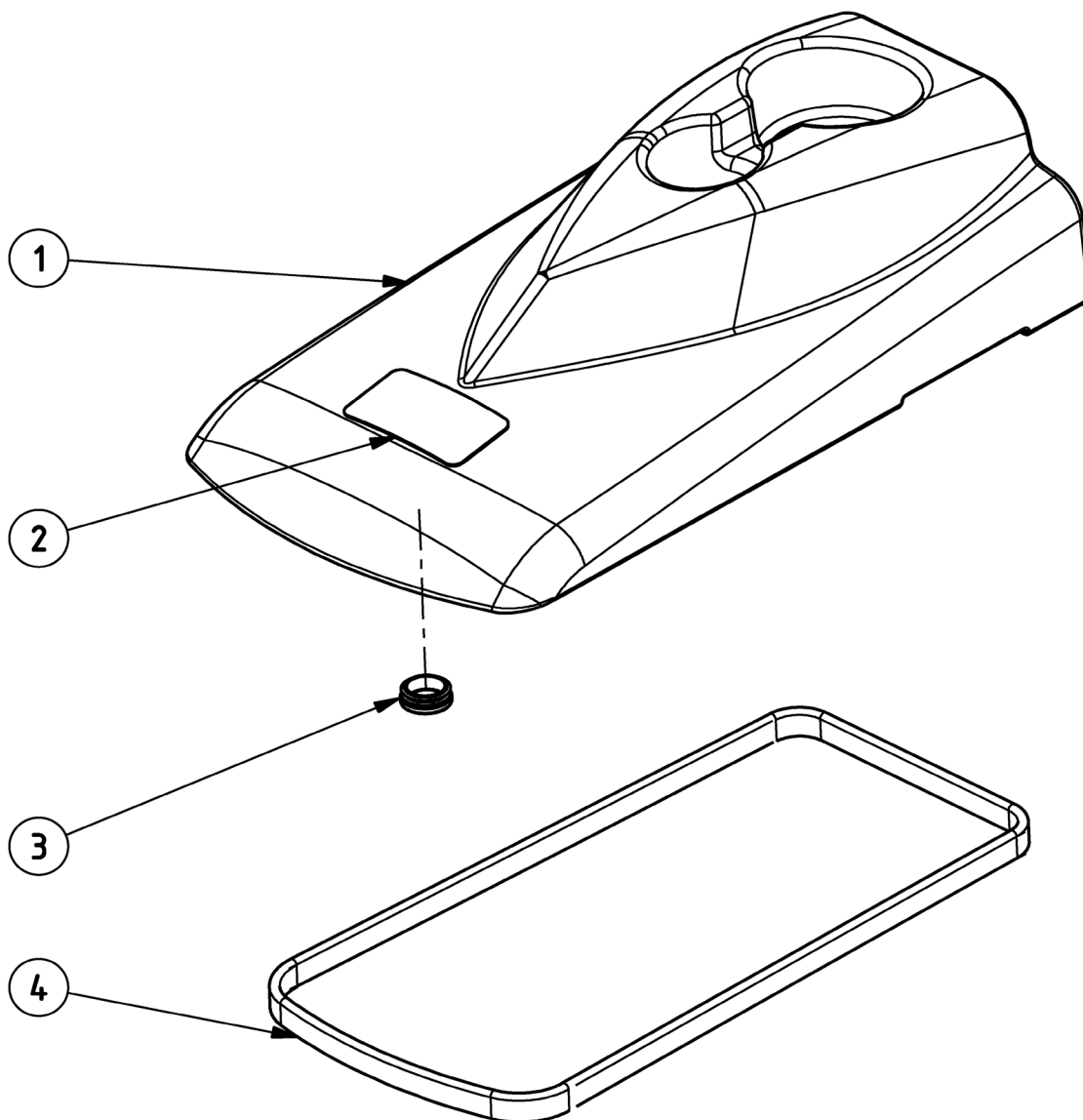

COVER TANK ASSEMBLY

DIA NO.	PART NUMBER	DESCRIPTION	SERIAL NUMBER	NO. REQ'D
1	8012005B	COVER TANK		1
2	8012003	WARNING LABLE		1
3	8011005	CAP		1
4	8012002A	GASKET		1

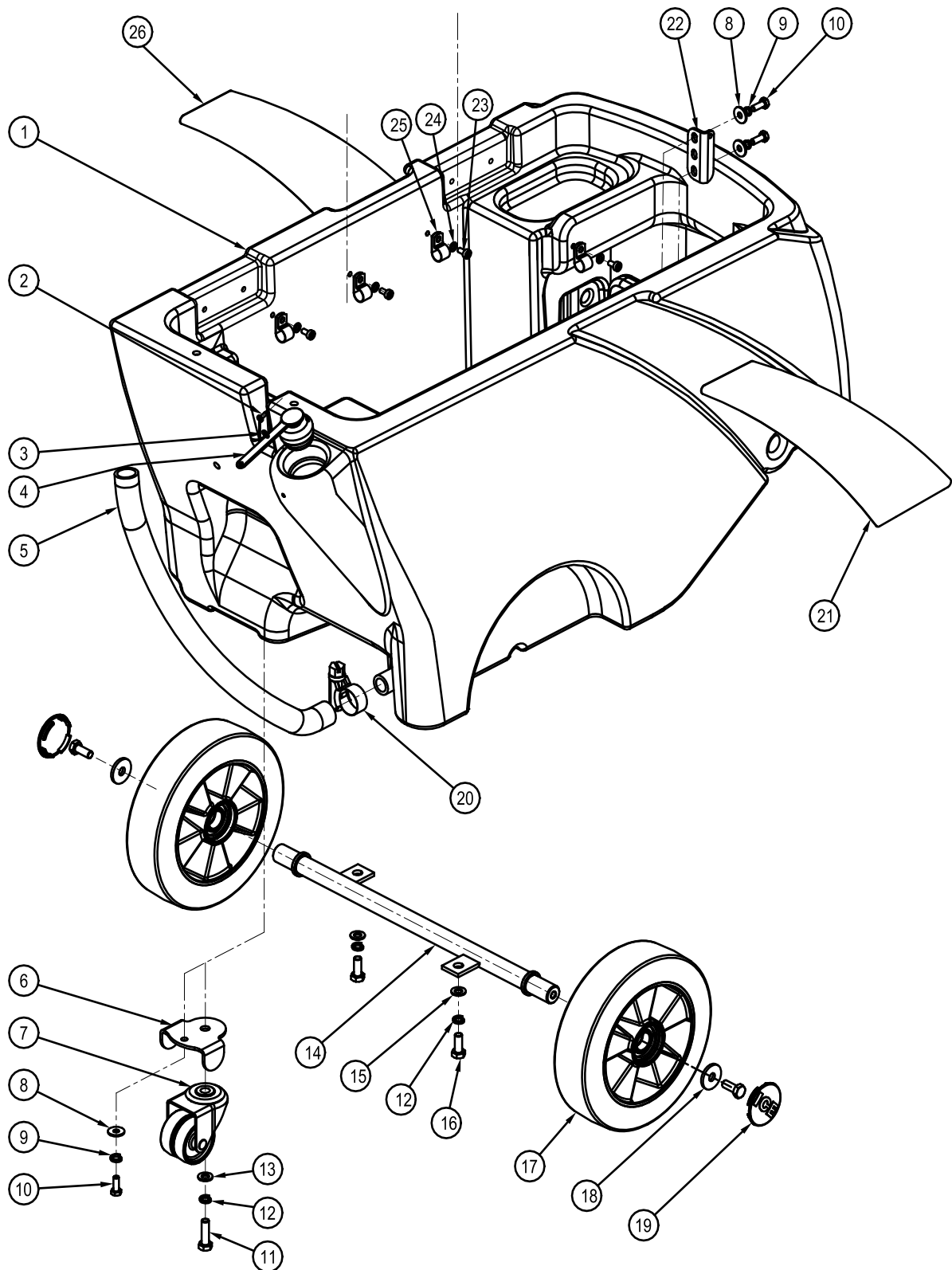
SOLUTION TANK GROUP

PARTS LIST**SOLUTION TANK GROUP**

DIA NO.	PART NUMBER	DESCRIPTION	SERIAL NUMBER	NO. REQ'D
1	8013001B	SOLUTION TANK	51020000173—51020000421	1
	8017001B	SOLUTION TANK,Blue	18HD-000422—	1
2	1321110	AUTO TAPPING SCREW ST3.5×10		1
3	1421409	PLAIN WASHER φ4×φ9×0.8		1
4	8133002	PLUG		1
5	8013005	TRANSPARENT HOSE		1
6	8034012	BRACKET, CASTER		1
7	8013016	2" CASTER		1
8	1421618	PLAIN WASHER φ6×φ18×1.6		3
9	1422616	SPRING WASHER 6 SS		3
10	1021616	HEX HEAD SCREW M6×16,SS		3
11	1021830	HEX HEAD SCREW M8×30,SS		1
12	1422821	SPRING WASHER 8		3
13	1421824	PLAIN WASHER φ8×φ24×2.0		1
14	8016010	WHEEL SHAFT		1
15	1421816	PLAIN WASHER φ×1φ6×1.6		2
16	1021820	HEX HEAD SCREW M8×20,SS		4
17	8115200	8" WHEEL		2
	1612607	BALL BEARING, 6004LU		4
18	1421828	PLAIN WASHER φ8×φ28×3		2
19	8115206	WHEEL CAP		2
20	1962032	HOSE CLAMP		1
21	8023004	DECAL,RIGHT		1
22	8013002	BACKET		1
23	1221510	PH SCREW M5×10,SS		4
24	1421510	PLAIN WASHER φ5×φ10×1,SS		4
25	8113009	WIRE CLAMP		4
26	8023003	DECAL,LEFT		1

CONTROL BOX ASSEMBLY

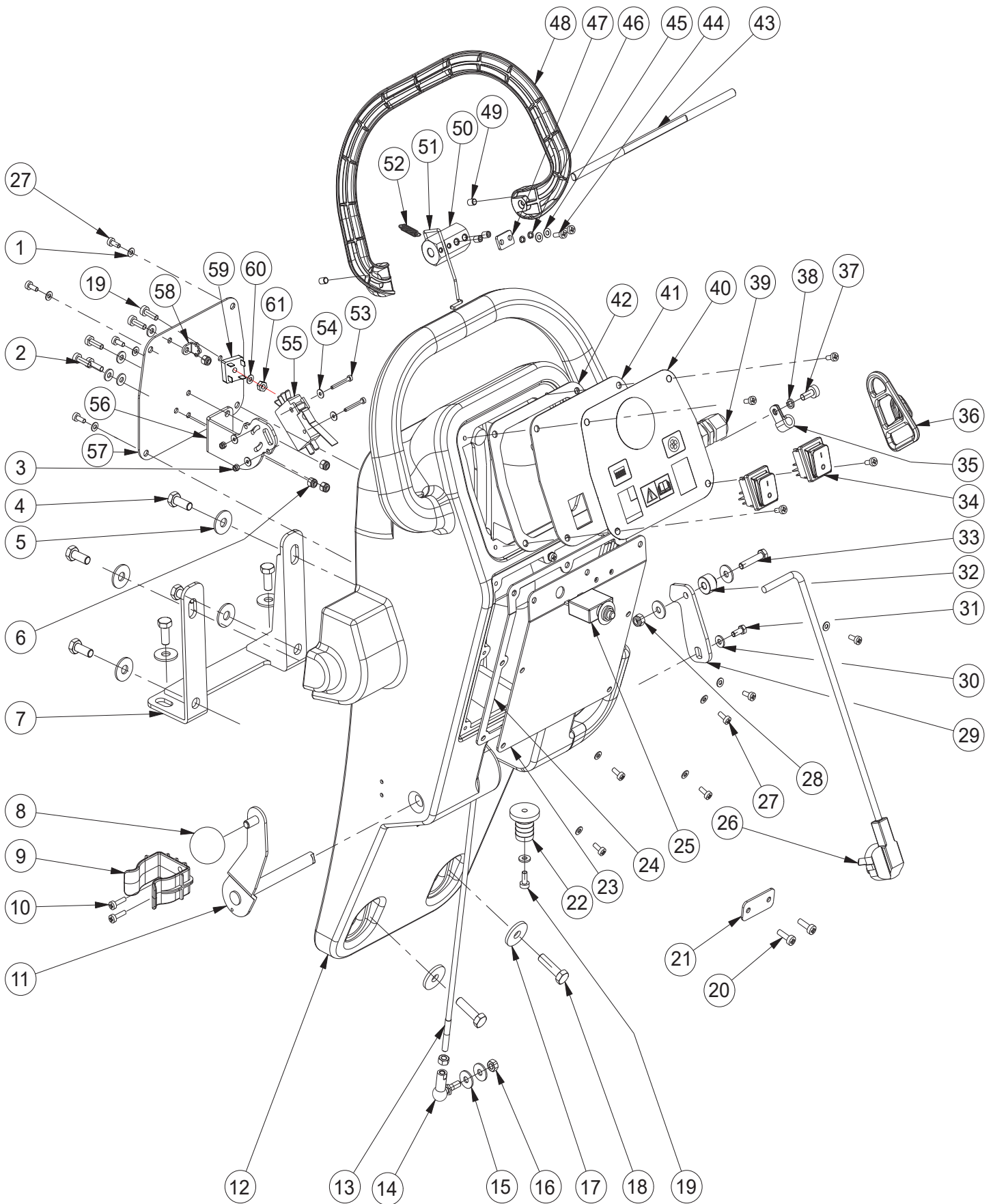

PARTS LIST

CONTROL CONSOLE GROUP

DIA NO.	PART NUMBER	DESCRIPTION	SERIAL NUMBER	NO. REQ'D
1	1421409	PLAIN WASHER 4×9×0.8		11
2	1211516	PH SCREW M5×16		4
3	1113305	SELFLOCKING NUT M3		2
4	1021820	HEX HEAD BOLT M8×20		6
5	1411824	PLAIN WASHER 8×24×2		6
6	1113507	SELFLOCKING NUT M5		4
7	8114030	FIXING BRACKET,CONTROL BOX		1
8	8113104	HANDLE		1
9	6210111	HOSE CLAMP	51020000173—51020000793	1
	6210120	HOSE CLAMP	51020000794—	1
10	1221416	PH SCREW M4×16 SS		2
11	8014010	SQUEEGEE LIFTING HANDLE		1
12	8014008	CONTROL BOX		1
13	8034010	SQUEEGEE LIFTING ROPE		1
14	8114511	JOINT BEARING SQ6		1
15	1421618	PLAIN WASHER 6×18×1.6,SS		4
16	1121605	HEX NUT M6		2
17	1421828	PLAIN WASHER 8×28×3		2
18	1021830	HEX HEAD BOLT M8×30		2
19	1221512	PH SCREW M5×12		2
20	1221516	PH SCREW M5×16 SS		2
21	8014044	PLATE		1
22	8114005	PIPE COUPLING		1
23	8014037	PANEL, BOTTOM		1
24	8014038	GASKET		1
25	8014068	OVERLOAD PROTECTOR 10A		1
26	8014053	Power Cord, 82' 14AWG Water Resistant		1
	8014058	Pigtail Kit		1
27	1221410	PH SCREW M4×10,SS		15
28	1123608	SELFLOCKING NUT M6,SS		1
29	8034011	BAFFLE		1
30	1421512	PLAIN WASHRE 5×12×1.5		8
31	1021512	HEX HEAD BOLT M5×12,SS		1
32	8014101	LIFTING ROPE SPACER		1
33	1021630	HEX HEAD BOLT M6×30,SS		1
34	8014006	WATERPROOF SWITCH 250V 16A		2
35	8014041	WIRE CLAMP		1
36	8014043	WIRE BUFFER		1
37	1221614	PH SCREW M6×14		1
38	1422616	SPRING WASHER 6		1
39	2320403	STRAIN RELIEF		1
40	8024002	PANEL DECAL		1

CONTROL CONSOLE GROUP

DIA NO.	PART NUMBER	DESCRIPTION	SERIAL NUMBER	NO. REQ'D
41	8014005	FRONT PANEL		1
42	8014004	GASKET		1
43	8114101	SHAFT		1
44	1221412	PH SCREW M4×12,SS		2
45	1411409	PLAIN WASHRE 4×9×0.8		2
46	1432411	SPRING WASHER 4		2
47	8014033	PLATE		1
48	8024022	CONTROL TRIGGER		1
49	1534608	SET SCREW M6×8		4
50	8014031	HEX BUSHING		1
51	8014032	SPRING ROD		1
52	8014035	SPRING		1
53	1211325	PH SCREW M3×25		2
54	1411309	PLAIN WASHER 3×9×0.8		4
55	8014071	SWITCH		1
56	8014061	SWITCH BRACKET		1
57	8014002	REAR PANEL		1
58	8014034	BRACKET		1
59	6210423	RECTIFIER		1
60	1421510	PLAIN WASHER 5×10×1,SS		1
61	1123507	LOCK NUT M5		1

Note:

DIA NO 9:Supplier change, code update.

SCRUB HEAD GROUP

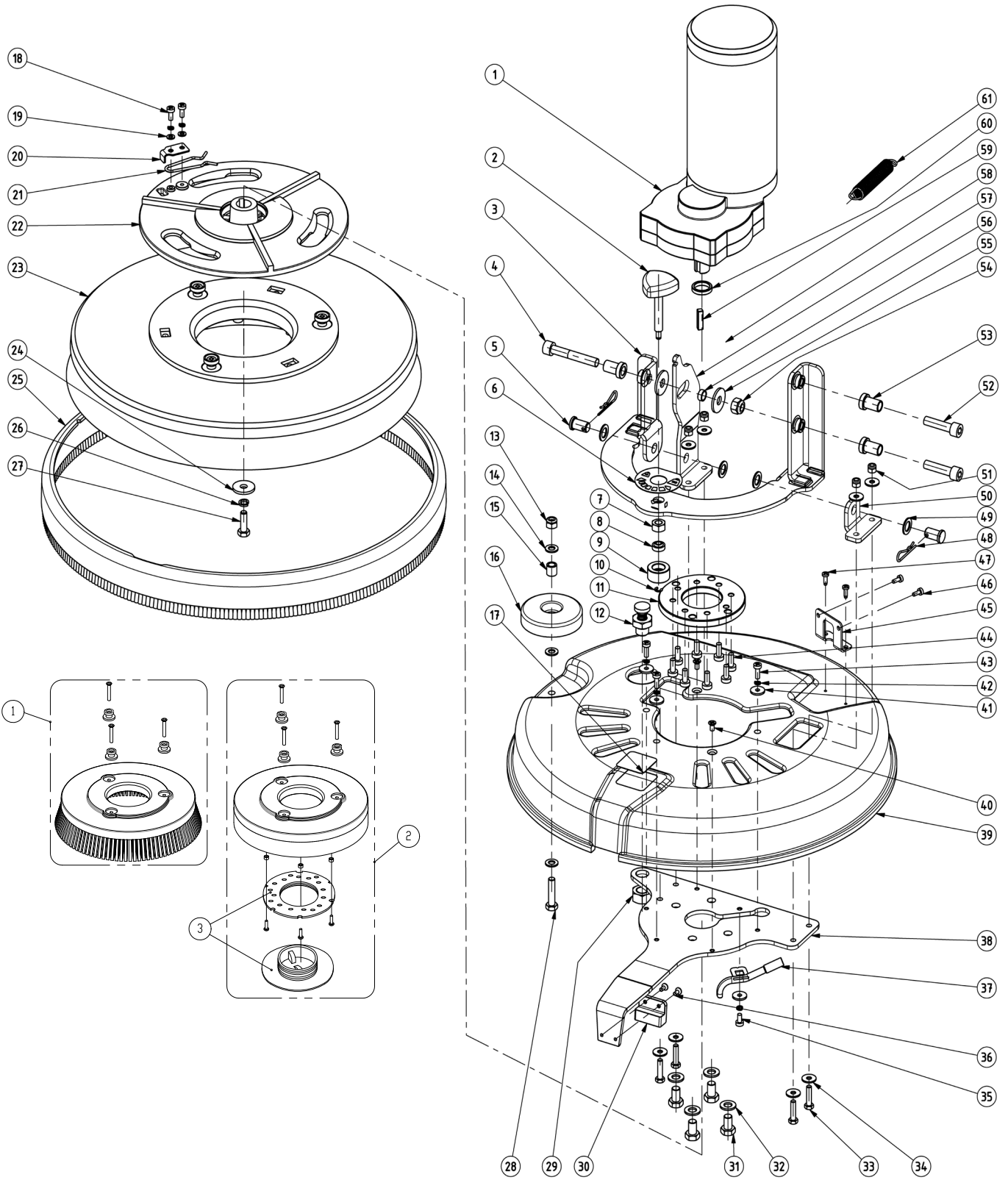

SCRUB HEAD GROUP

DIA NO.	PART NUMBER	DESCRIPTION	SERIAL NUMBER	NO. REQ'D
1	8015220	MOTOR 120V 550W, KIT		1
2	8015020	ADJUSTING HANDLE		1
3	8015010	BRUSH HANGER		1
4	1511065	HEX SOCKET SCREW M10×65		1
5	1644220	PIN 12×20		2
6	8015101	DECAL		1
7	1111008	HEX NUT M10		1
8	8015104	BEARING GEC6C		1
9	8015105	BEARING HOUSING		1
10	1439005	DETENT RING 5		1
11	8015087	ASSAMBLY BOARD		1
12	8015050	BRUSH PLUNGER		1
13	1123810	SELFLOCKING NUT M8,SS		1
14	1421816	PLAIN WASHER φ8×φ16×1.6,SS		3
15	8115404	SPACER		1
16	8116078	BUMPING WHEEL		1
17	8111023	WARNING DECAL		1
18	1221512	PH SCREW M5×12		2
19	1421510	PLAIN WASHER φ5×φ10×1,SS		2
20	8116002	WASHER		1
21	8116003	SPRING CLAMP		1
22	8116008	BRUSH HUB		1
23Δ	9050018	BRUSH 18"		1
24	1421828	PLAIN WASHER φ8×φ28×3		1
25	8015090	SPLASH GUARD		1
26	1422821	SPRING WASHER 8		1
27	1023810	HEX HEAD BOLT 5/16×1",SS		1
28	1021835	HEX HEAD BOLT M8×35,SS		1
29	1111215	HEX NUT M16		1
30	8015108	SUPPORTER		1
31	1011016	HEX BOLT M6×16		1
32	1411020	PLAIN WASHER φ10×φ20×2		4
33	1011625	HEX HEAD BOLT M6×25		4
34	1421618	PLAIN WASHER φ6×φ18×1.6,SS		8
35	1221510	SH SCREW M5×10		1
36	1212410	SH SCREW M4×10		2
37	8015060	WATER INLET		1
38	8015041	MOTOR BRACKET		1
39	8015005	BRUSH COVER		1
40	1222510	SH SCREW M5×10		2
41	1421518	PLAIN WASHER φ5×φ18×2,SS		4
42	1422513	SPRING WASHER 5		5
43	1221515	PH SCREW M5×15		3
44	1221616	PH SCREW M6×16		8
45	8015103	VALVE BRACKET		1
46	1221410	PH SCREW M4×10,SS		2
47	1321213	AUTO TAPPING SCREW ST4.2×13		2

PARTS LIST

SCRUB HEAD GROUP

DIA NO.	PART NUMBER	DESCRIPTION	SERIAL NUMBER	NO. REQ'D
48	1646240	COTTER PIN 2×40		2
49	8015116	NYLON WASHER φ12.5×φ20×1.5		4
50	8015001	BRACKET		1
51	1123608	SELFLOCKING NUT M6,SS		4
52	1511040	HEX SOCKET SCREW M10×40		2
53	8015007	BUSHING		3
54	1113012	SELFLOCKING NUT M10		1
55	8015115	NYLON WASHER φ10.5×φ30×2.5		2
56	8015121	SPACER 13×10.5×5.5		1
57	8015002	BRACKET		1
58	8116004	DETENT RING		1
59	1656432	KEY 6.35×32		1
60	8015003	SPACER 25.5×19.5×5		1
61	8115004	SPRING		1

23 △

DIA NO.	PART NUMBER	DESCRIPTION	SERIAL NUMBER	NO. REQ'D
1	9050018	BRUSH 18"		1
2	9040017	PAD DRIVER 17"		1
3	9000001	BIG MOUTH		1

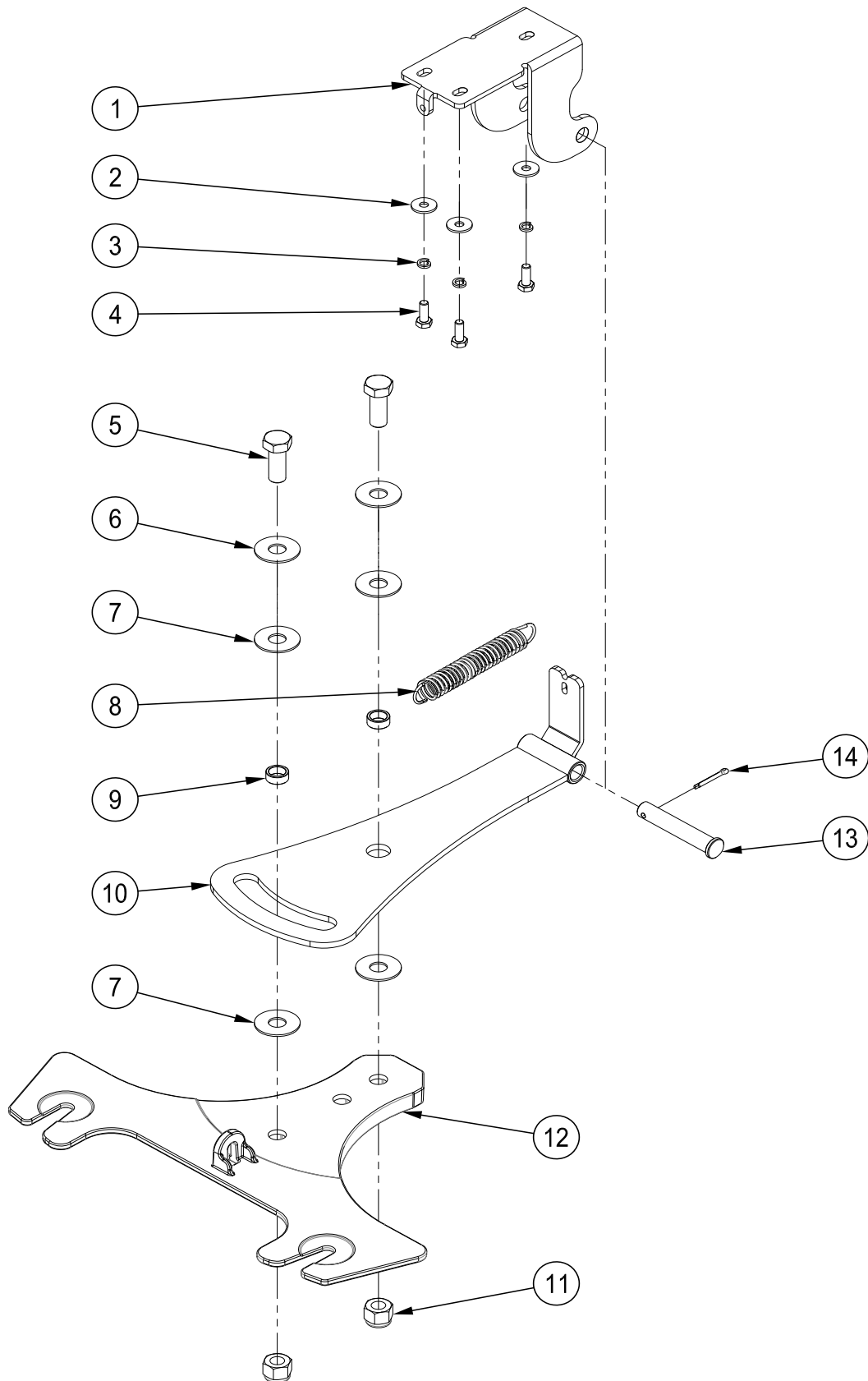
SQUEEGEE HOLDER ASSEMBLY

PARTS LIST

SQUEEGEE HOLDER ASSEMBLY

DIA NO.	PART NUMBER	DESCRIPTION	SERIAL NUMBER	NO. REQ'D
1	8037020	BRACKET, SQUEEGEE MNTG		1
2	1421618	PLAIN WASHER 6×18×1.6		3
3	1422616	SPRING WASHER 6 SS		3
4	1021616	HEX HEAD SCREW M6×16,SS		3
5	1021230	HEX HEAD BOLT M12×30,SS		2
6	1421132	PLAIN WASHER 12×32×2.0		2
7	8035001	PLASTIC WASHER 12×30×1.5		4
8	8115004	SPRING		1
9	8115405	SLEEVEE, P/M	51020000101—51020000172	2
	8115005	SLEEVEE, P/M	51020000173—	2
10	8037010	BRACKET, SQUEEGEE		1
11	1123115	SELFLOCKING NUTS M12		2
12	8115001	SQUEEGEE SUPPORT		1
13	8037015	PIN 12×70		1
14	1645324	COTTER PIN		1

Note:

NO 9: The results are optimized and will also fit older machines.

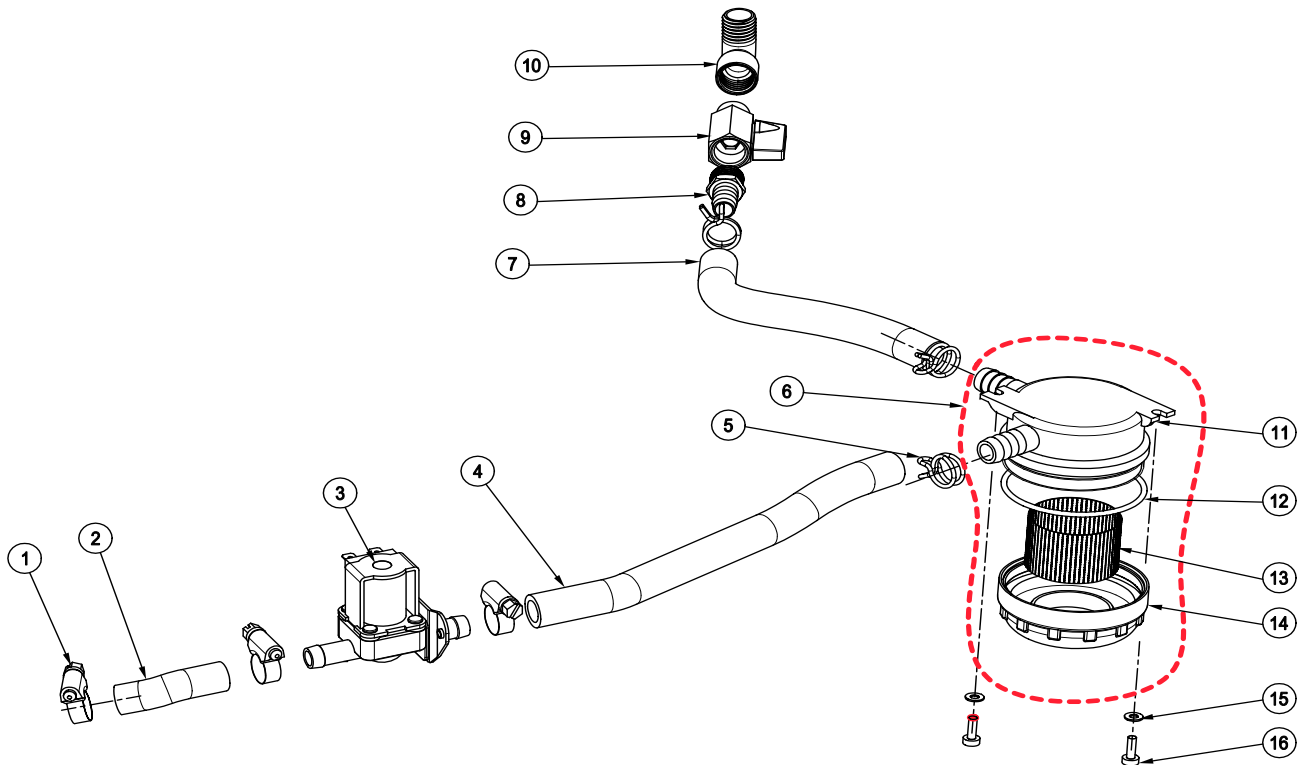
SOLUTION SYSTEM ASSEMBLY**SOLUTION SYSTEM ASSEMBLY**

DIA NO.	PART NUMBER	DESCRIPTION	SERIAL NUMBER	NO. REQ'D
1	1962016	HOSE CLAMP		2
2	8018004	HOSE		1
3	8018009	SOLENOID VALVE, 110V		1
4	8018003	HOSE		1
5	8119006	HOSE CLAMP		4
6	8119200	WATER FILTER		1
7	8018002	HOSE		1
8	8013007	JOINT		1
9	8018006	BALL VALVE		1
10	8013006	90° JOINT		1
11	8119101	FILTER BODY		1
12	1622765	O RING		1
13	8119104	FILTER SCREEN		1
14	8119102	FILTER COVER		1
15	1421409	PLAIN WASHER 4×9×0.8,SS		2
16	1221412	PH SCREW M4×12, SS		2

SQUEEGEE ASSEMBLY

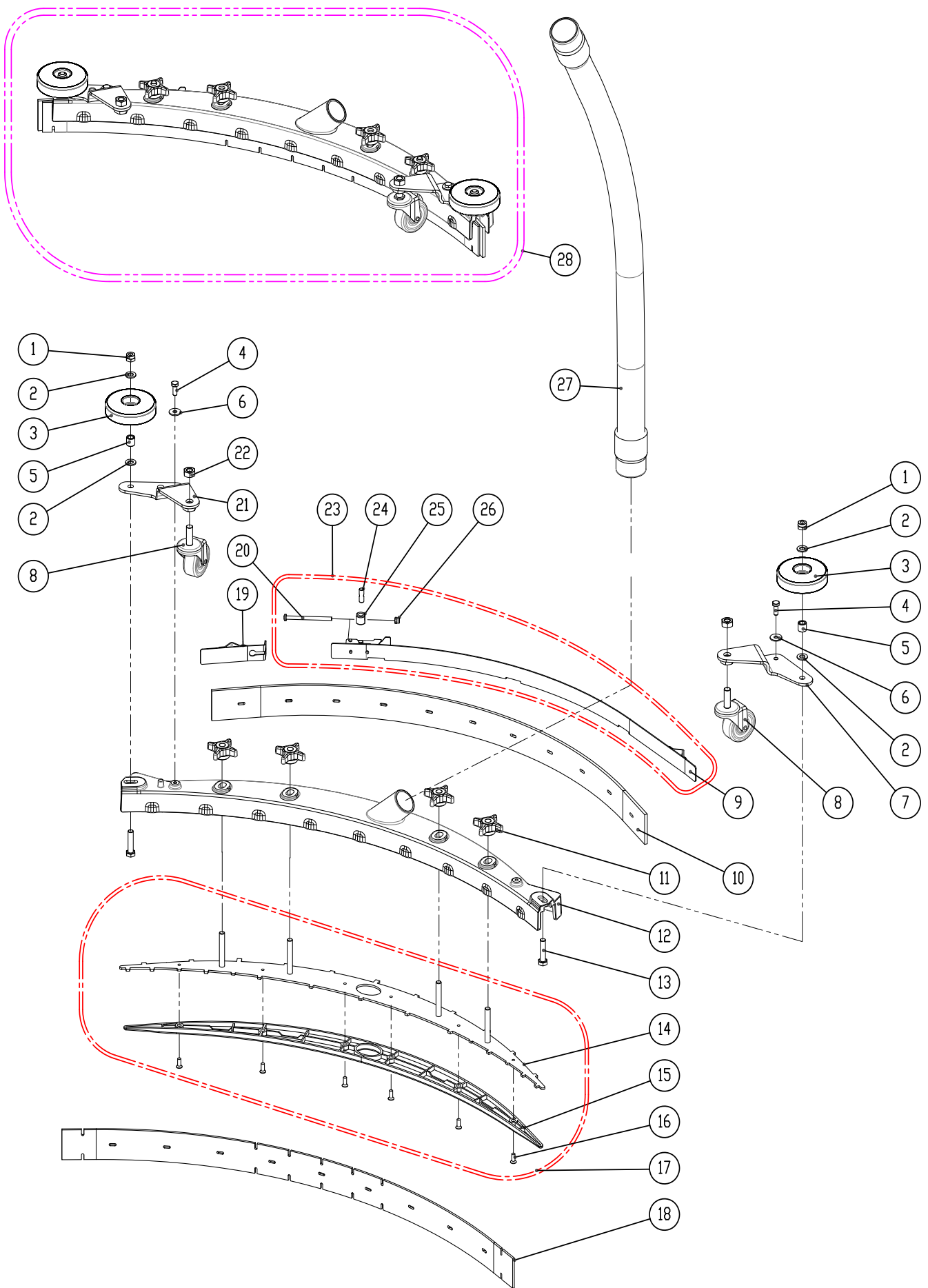

SQUEEGEE ASSEMBLY

DIA NO.	PART NUMBER	DESCRIPTION	SERIAL NUMBER	NO. REQ'D
1	1123810	LOCK NUT M8		2
2	1421824	FLAT WASHER M8×φ24×2.0		4
3	8116078	PROTECTIVE WHEEL		2
4	1021616	HEX BOLT M6×16		2
5	8115404	BEARING, JOURNAL		2
6	1421612	FLAT WASHER M6×φ12×1.6		2
7	8118300	LEFT BRACKET		1
8	8118400	CASTER, 2 INCH		2
9	8118600	CLAMP ASSEMBLY, SQUEEGEE		1
10	8118022	SQUEEGEE BLADE, REAR, LINATEX		1
	8118002	SQUEEGEE BLADE, REAR, PU (OPTION)		1
11	8118003	STAR KNOB M8		4
12	8118004	SQUEEGEE HOUSING		1
13	1021835	HEX BOLT M8×35		2
14	8118009	RETAINER,SQUEEGEE		1
15	8118008	SPACER		1
16	1222515	SCREW M5×15		6
17	8118010	RETAINER ASSEMBLY		1
18	8118021	SQUEEGEE BLADE, FRONT, LINATEX		1
	8118001	SQUEEGEE BLADE, FRONT, PU (OPTION)		1
19	8118610	SHORT CLAMP ASSEMBLY		1
20	1221575	SCREW M5×75		1
21	8118200	RIGHT BRACKET		1
22	1121008	HEX NUT M10		2
23	8118600A	CLAMP ASSEMBLY		1
24	8118624	SHAFT		1
25	8118623	SPACER		1
26	1123507	LOCK NUT M5		1
27	8011003	VACUUM HOSE		1
	8011060	VACUUM HOSE		1
28	8118000	SQUEEGEE ASSEMBLY, LINATEX		1
	8118000-PU	SQUEEGEE ASSEMBLY, PU		1

Note:

DIA NO 27:Supplier change, code update.

PARTS LIST

WEAR & TEAR PARTS LIST

DIA NO.	PART NUMBER	DESCRIPTION	SERIAL NUMBER	NO. REQ'D
1	8115200	WHEEL, 8 INCH, WITH BEARINGS		2
2	8116078	BUMPER, ROLLER		3
3	8118022	REAR SQUEEGEE BLADE, LINATEX		1
4	8118021	FRONT SQUEEGEE BLADE, LINATEX		1
5	9040017	PAD HOLDER, 17 INCH		1
6	9050018	BRUSH, 18 INCH		1

CERTIFICATE OF QUALIFIED

MODEL: _____ SERIAL NO.: _____

INSPECTOR: _____ DATE: _____

ICE Cobotics (GuangDong)Company Limited

TEL:(+86) 769 8186 9000 FAX:(+86) 769 8186 3000